

# Digital Optical Module & System Design for a Km-Scale Neutrino Detector in Ice

D.M. Lowder<sup>1,5</sup>, K.H. Becker<sup>6</sup>, D. Cowen<sup>3</sup>, C. Guenther<sup>5</sup>, V. Drozdov<sup>2</sup>, J. Jacobsen<sup>5</sup>, A. Karle<sup>4</sup>,  
 H. Leich<sup>2</sup>, J. Ludvig<sup>5</sup>, C. McParland<sup>5</sup>, H.S. Matis<sup>5</sup>, A. Mihalyi<sup>3</sup>, R. Morse<sup>4</sup>, D. Nygren<sup>5</sup>,  
 G. Przybylski<sup>5</sup>, P. Robl<sup>4</sup>, X. Ryppa<sup>5</sup>, T. Schmidt<sup>2</sup>, U. Schwendicke<sup>2</sup>, G. Smoot<sup>1,5</sup>, C. Spiering<sup>2</sup>,  
 T. Stezelberger<sup>5</sup>, R. Stokstad<sup>5</sup>, R. Tomschitz<sup>5</sup>, and A. Torschmied<sup>5</sup>

<sup>1</sup>*Dept. of Physics, UC Berkeley, Berkeley, CA 94720, USA*

<sup>2</sup>*DESY-Institute for High Energy Physics, Zeuthen, Germany*

<sup>3</sup>*Dept. of Physics, University of Pennsylvania, Philadelphia, PA 19104, USA*

<sup>4</sup>*Dept. of Physics, University of Wisconsin, Madison, WI 53706, USA*

<sup>5</sup>*Lawrence Berkeley National Laboratory, Berkeley, CA 94720, USA*

<sup>6</sup>*University of Wuppertal, Wuppertal, Germany*

## Abstract

A technology for a km-scale high-energy neutrino telescope can be implemented using an all-digital design with copper-based links between photomultiplier tubes (PMTs) and the surface. We describe here the main features of this technology, including general system architecture and specific electronic circuitry for PMT signal processing. The general performance goal is the capture of PMT information, including waveforms, with high dynamic range and order 1 ns timing accuracy. Potential benefits of this approach include high quality data, simple connectivity, high reliability, low construction costs, and low power use. This technology also enables the use of a local time-coincidence among neighboring PMTs to greatly reduce bandwidth and signal processing requirements. We are implementing this concept with the construction of a prototype string of PMTs to be deployed at the South Pole in the 1999-2000 season.

—

When considering a general systems engineering approach to design a km-scale neutrino detector, a decentralized architecture based on a semi-autonomous Digital Optical Module (DOM) concept appears to offer reliability and functional advantages. The basic ideas are described elsewhere (Chaloupka 1996, Nygren 1998).

Specifically, the system described here is designed to achieve the following goals:

- Measure the arrival time and pulse height of PMT signals with timing accuracy limited by the intrinsic timing jitter of the PMT itself (typically 4 nsec FWHM) and with a dynamic range of at least 100 photoelectrons (p.e.);
- Achieve the above by digitizing PMT signals within optical modules (OMs) and providing circuitry that allows events within an OM to be measured with nanosecond accuracy relative to a single surface clock over a twisted-pair electrical cable;
- Provide waveform information from the PMT over short ( $\sim 300$  nsec) and long ( $\sim 3$   $\mu$ sec) time scales for interesting events with large detected signals, such as large electromagnetic showers produced by  $\nu_e$  interactions;
- Provide blue or ultraviolet LEDs within each OM that can be pulsed to give calibration signals both for local OMs and for OMs on neighboring strings;
- Provide links between neighboring OMs on a string that enable “local coincidence” (LC), i.e. nearest-neighbor or next-to-nearest-neighbor coincidences, to be detected.

Such a system would provide high-quality, detailed information from each OM, would have a high degree of flexibility in triggering, would not require the use of expensive optical fiber cables, and, through the local coincidence, reduce the amount of information that needs to be sent from OM to surface.

We are constructing a prototype string of DOMs based on these concepts that will be deployed at the South Pole in January 2000. This prototype string is designed to achieve the goals outlined above, and will have some additional hardware and software to aid in testing these concepts:

- Each DOM will have an individual twisted-pair cable to the surface, and will be able to run in a mode where every single p.e. pulse from the PMT will be digitized and sent to the surface. This will be important in understanding how local coincidence operation affects triggering and event-building at the surface.
- The PMT inside each DOM will be read out in parallel by an optical transducer that sends an analog pulse to the surface over fiber optic cable, in the same manner as is done in the standard AMANDA OM design, and these pulses will be received and recorded by the full AMANDA data acquisition system. This will allow direct comparison between data recorded by AMANDA and data recorded by the prototype digital string.

Figure 1a shows a schematic of the DOM string. DOMs are arranged 10 m apart, with individual twisted-pair connections to the surface, and local coincidence cables provided between neighboring DOMs. The DOM is shown in figure 1b. It consists of an 8" Hamamatsu PMT mounted in a spherical pressure vessel, with electronics boards to digitize signals from the PMT and send information to the surface.

Figure 2 shows a block diagram of the electronics contained inside the DOM. The PMT is powered by a custom base circuit with high voltage produced on the base and CPU-controlled. The voltage divider has very high resistance and actively stabilized dynodes to produce low power consumption and high dynamic range. PMT signals are routed through a transformer coupling into a custom integrated circuit, the analog transient waveform digitizer (ATWD). When triggered, this circuit takes 128 samples of the voltage at each of its inputs, with sample width typically 3 ns and externally adjustable. The ATWD receives both amplified and unamplified signals from the PMT at separate inputs, allowing high dynamic range ( $> 100$  p.e.) to be achieved. Another copy of the PMT signal goes into a shaping amplifier and is then digitized for  $\sim 3 \mu\text{sec}$  with 30 nsec sample width by an 8-bit flash ADC. A field-programmable gate array (FPGA) controls readout of the ATWD and flash ADC in response to information from the trigger circuit. A low-power CPU is used to start up the DOM at power-on, program the FPGA, and provide slow control functions (high voltage, thresholds, voltage monitoring, etc.). The FPGA is also used to provide high-speed communications to the surface through the ADC/DAC and line driver/receiver shown in the figure. Only a single twisted pair runs from the DOM to the surface, providing both DC power and communications.

To determine the arrival time of PMT signals in the DOM relative to a master clock on the surface, an extremely stable local clock is used to clock the CPU and FPGA. This clock is a precision Toyocom free-running oscillator running at  $\sim 18$  MHz that has short-term stability of order  $10^{-11}$ , so will drift no more than 1 nsec over a time interval of a minute or more; therefore synchronization with the surface need be done only at 1 minute intervals. During this time calibration, communications will be turned off for a brief time, a pulse will be sent from the surface to the DOM, its time of arrival measured by the local clock, and after a fixed, precise delay, an identical pulse will be sent to the surface, and the surface arrival time measured by the master clock in the same way (figure 3). Provided that the twisted-pair cable is symmetric in response, as current evidence indicates that it should, this provides an unambiguous way of relating the local clock in the DOM to the master clock on the surface (Stokstad 1998). The remaining unknown, the PMT transit time, will be measured using the LED pulser circuit on board the DOM. The main technical difficulty is the long rise time of a pulse that traverses 2 km of twisted pair, which is of order  $1 \mu\text{sec}$ . The solution is to sample the waveform of the received calibration pulse and fit the leading edge to its characteristic exponential shape to

determine the start time of the pulse to accuracy of a few nsec. Our tests indicate that with properly designed line drivers/receivers, the signal/noise on the twisted pair cable used will be adequate to do this.

The surface system will include a compact PCI crate with custom frontend and readout boards, and be operated by a PC running Linux (see figure 4). The system will perform software triggering of the digital string, event building, and disk and tape storage of events, will control the time calibration of the DOM string in synchronization with a GPS clock, and will receive trigger inputs from AMANDA and from SPASE (South Pole air shower experiment) to enable direct comparison of DOM data with data from these experiments.

As of this writing (May 1999) we have constructed prototype DOM electronics boards and have begun to test them. Design and construction of the surface readout system is under way as well. We will be integrating the electronics with the phototube assembly for 50 DOMs in July and August, and will deploy a string of 42 DOMs in January 2000.

## References

Chaloupka, V., *et al.* 1996, *Technology Development for a Neutrino Astrophysical Observatory*, Lawrence Berkeley National Lab report LBL-38321.  
 Hill, G. *et al.* (The AMANDA collaboration) 1999, *Proc. 26th Int'l Cosmic Ray Conference*, HE.6.3.02.  
 Nygren, D. *et al.* 1998, *Digital Optical Module and System Design*, Lawrence Berkeley National Lab report LBNL-42013, available at <http://area51.berkeley.edu/manuscripts/>.  
 Stokstad, R., *et al.* 1998, *RAP - A Method for Absolute Time Calibration of a Large Array based on a Digital Optical Module System*, Lawrence Berkeley National Lab report LBNL-43200, available at <http://area51.berkeley.edu/~lowder/amanda/dom/>.

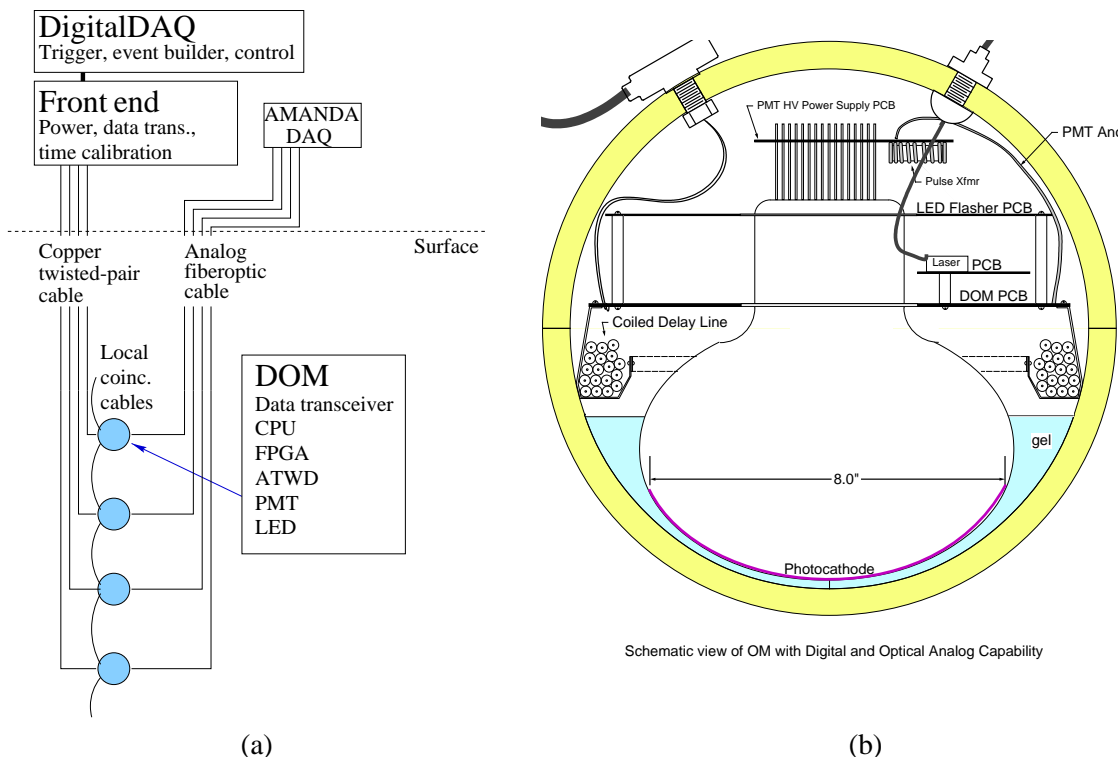

Figure 1: a. Schematic of the DOM string showing connections between the various components. b. Scale drawing of a DOM showing board placement.

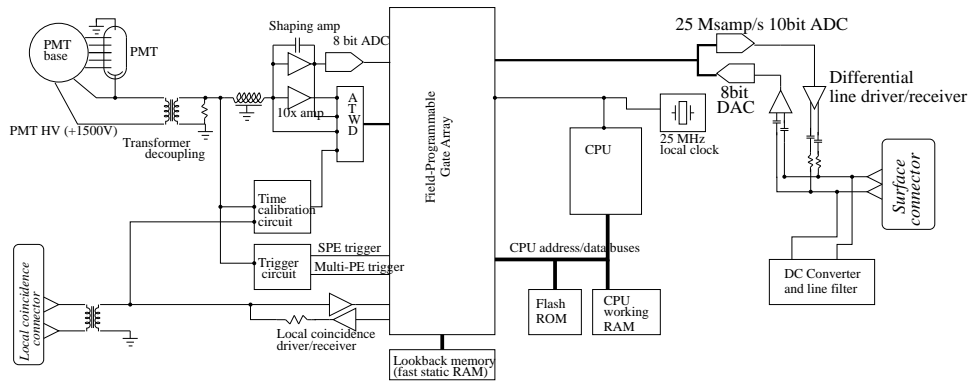

Figure 2: Simplified block diagram of the DOM electronics. Some circuitry (e.g. analog optical link, boot ROM and PLD, slow control circuitry, etc.) is not shown for clarity.

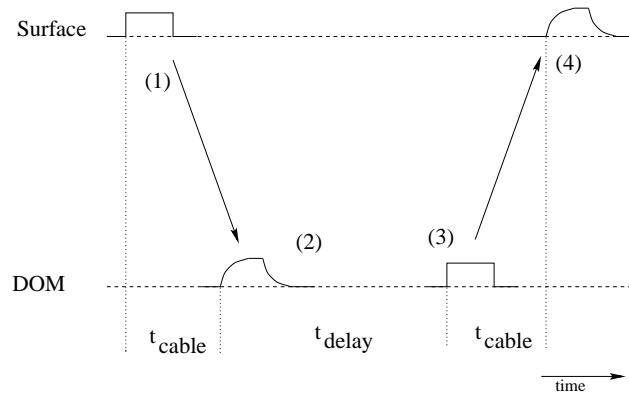

Figure 3: The “reciprocal active pulsing” (RAP) method of mapping local time within a DOM to a master clock time on the surface. (1) Surface sends pulse down the cable at time  $t=0$ , and records the master clock time. (2) DOM receives pulse at time  $t_{\text{cable}}$ , and records the local clock time. (3) After a fixed time  $t_{\text{delay}}$ , DOM sends a pulse identical to the original surface pulse up the cable. (4) Surface receives this pulse and records master clock time; total time elapsed =  $(2 \times t_{\text{cable}} + t_{\text{delay}})$ .  $t_{\text{cable}}$  can now be calculated, and the master clock time corresponding to the local time recorded in step (2) is known. Electronic hardware and software for transmitting, receiving, and analyzing time calibration pulses must be identical at both ends of the cable.

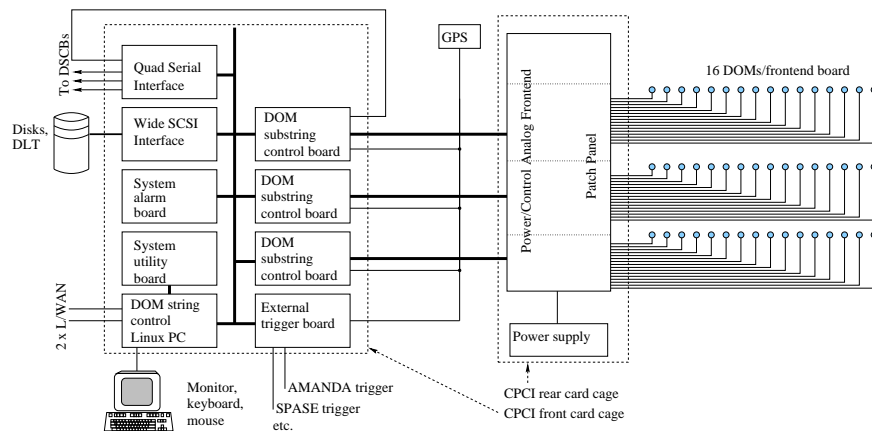

Figure 4: Schematic of the frontend and DAQ electronics on the surface.